

Building Sketch (Page - 1)

Borrower	N/A			
Property Address	130 Brookwynd Ct			
City	Garner	County Wake	State NC	Zip Code 27529
Lender/Client	N/A			

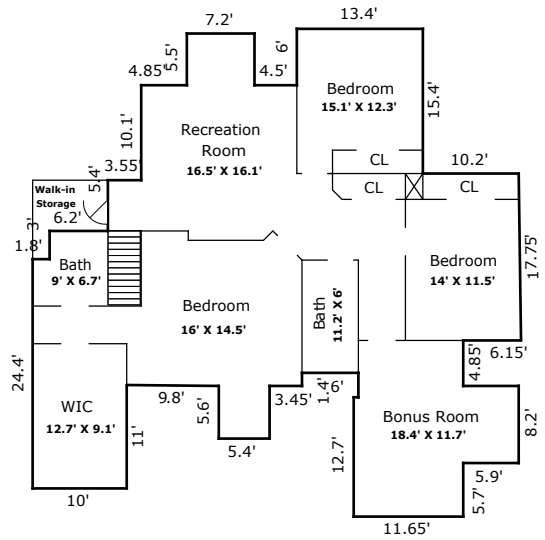
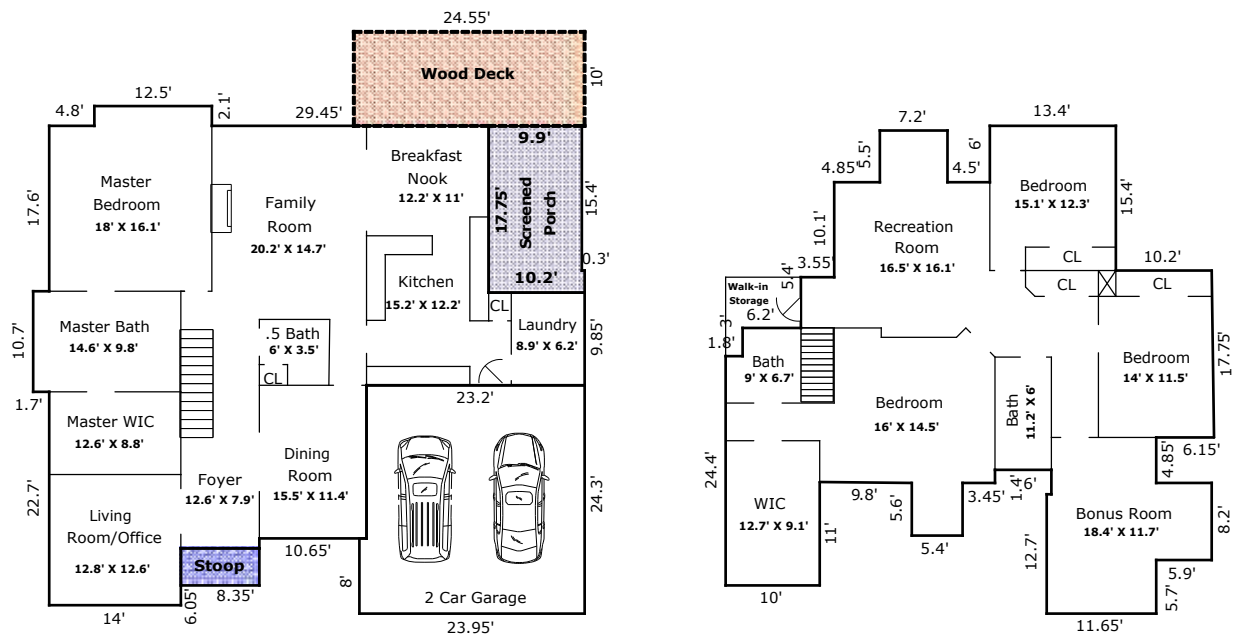

TOTAL Sketch by a la mode, inc.

Building Sketch (Page - 2)

Borrower	N/A			
Property Address	130 Brookwynd Ct			
City	Garner	County Wake	State NC	Zip Code 27529
Lender/Client	N/A			

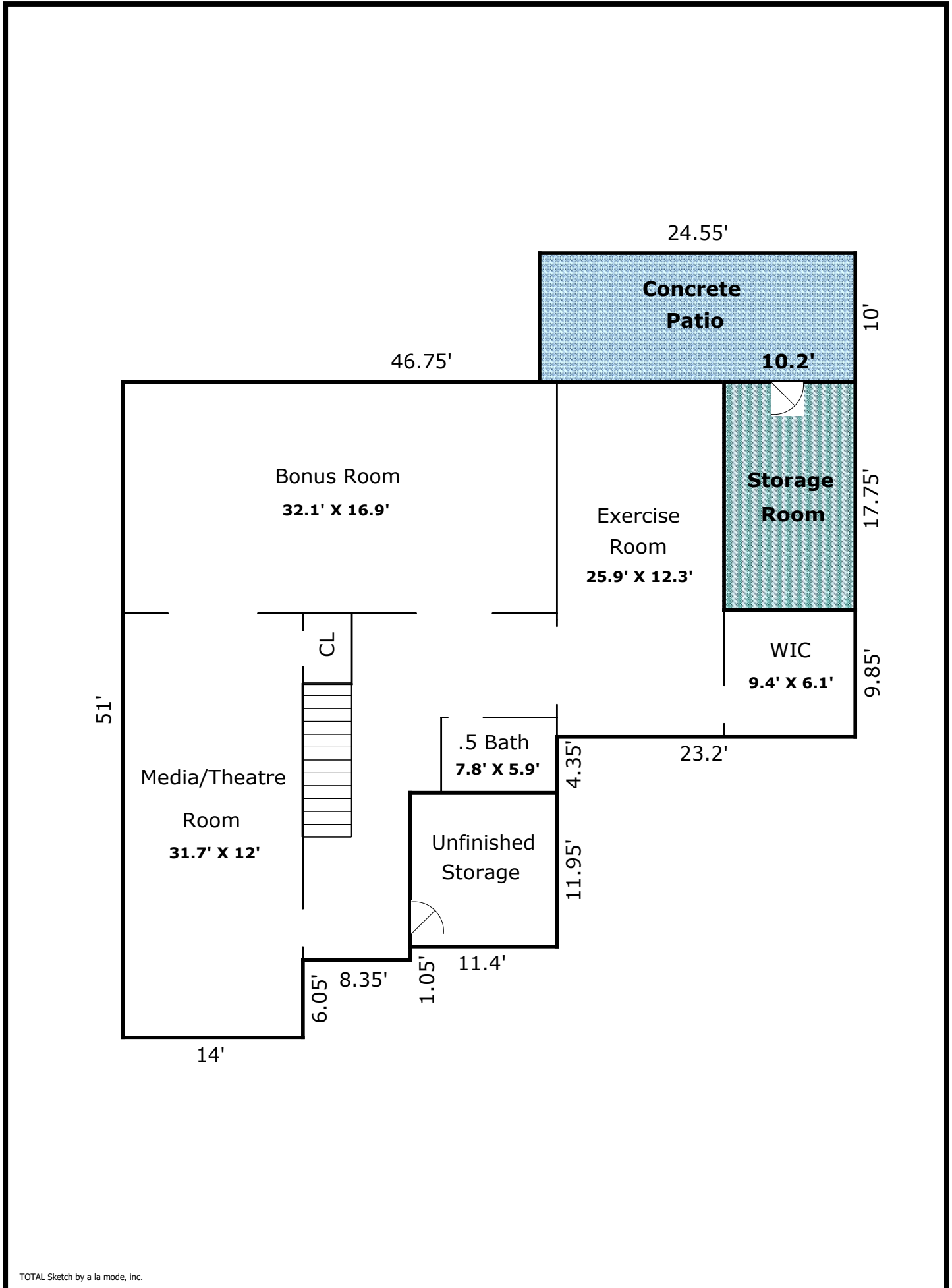

TOTAL Sketch by a la mode, inc.

Building Sketch (Page - 3)

Borrower	N/A			
Property Address	130 Brookwynd Ct			
City	Garner	County Wake	State NC	Zip Code 27529
Lender/Client	N/A			

TOTAL Sketch by a la mode, inc.

Area Calculations Summary

Living Area	Calculation Details		
First Floor	2093.5 Sq ft		
		10.7×1.7	= 18.19
		12.5×2.1	= 26.25
		9.85×10.2	= 100.47
		46.75×27.6	= 1290.3
		16.3×11.4	= 185.82
		22.35×17.35	= 387.77
		6.05×14	= 84.7
Second Floor	1826.93 Sq ft		
		7.2×5.5	= 39.6
		8.2×5.9	= 48.38
		5.4×5.6	= 30.24
		24.4×1.8	= 43.92
		27.4×6.2	= 169.88
		32.8×2	= 65.6
		$0.5 \times 0.02 \times 1.55$	= 0.01
		21.8×1.55	= 33.79
		$0.5 \times 0.08 \times 8.25$	= 0.35
		31.92×8.25	= 263.31
		32×8.3	= 265.6
		38×0.55	= 20.9
		36.6×6	= 219.6
		12.7×0.5	= 6.35
		51.9×6.85	= 355.52
		36.5×4.3	= 156.95
		17.75×5.9	= 104.72
		$0.5 \times 17.75 \times 0.25$	= 2.22
Total Living Area (Rounded):	3920 Sq ft		
Non-living Area			
Wood Deck	245.5 Sq ft	24.55×10	= 245.5
Screened Porch	176.43 Sq ft	9.9×15.4	= 152.46
		10.2×2.35	= 23.97
2 Car Attached	569.76 Sq ft	24.3×23.2	= 563.76
		8×0.75	= 6
Stoop	32.98 Sq ft	3.95×8.35	= 32.98
Concrete Patio	245.5 Sq ft	24.55×10	= 245.5
Finished Basement	1912.83 Sq ft	9.85×10.2	= 100.47
		46.75×27.6	= 1290.3
		23.4×14	= 327.6
		8.35×13	= 108.55
		4.35×19.75	= 85.91
Unfinished Basement	136.23 Sq ft	11.4×11.95	= 136.23
Storage Room	181.05 Sq ft	10.2×17.75	= 181.05